

**FK** **FUKE** 福客®

**FK-210D**

进取不止

**FUKE**

**Boutique Manufacturing  
Conquer The World With Quality**





# Outline

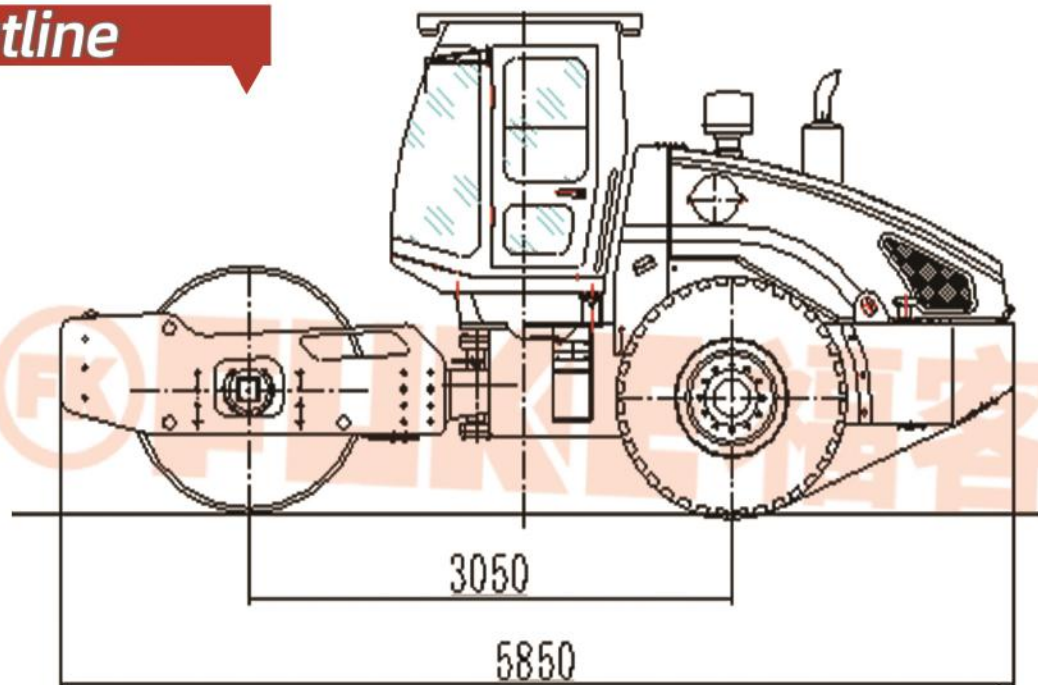

# Technical Specification

Operating weight	12000 kg
Diameter of vibrating drum	φ1450 mm
Rolling width	2100 mm
Activating force	245/125 KN
Vibration frequency	30 Hz
Theoretical amplitude of vibration	1.6/0.8 mm
Moving speed Range I II III IV	2.5/5.0/10.5 km/h
backward I	2.5/5.0 km/h
Gradeability	30%
Diesel engine model	Yuchai
Rated rotation speed	2000 r/min
Rated power	82 kw
Overall dimensions L*W*H	5850×2250×3080 mm

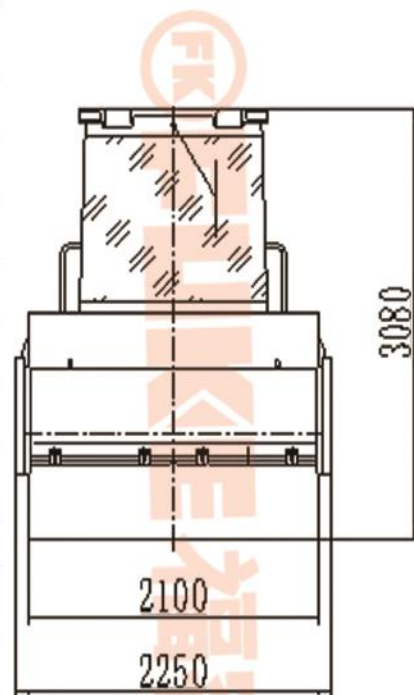

- ★ Mechanical drive, three-speed gears.
- ★ Hydraulic vibration, electronic controlled delayed starting of vibration, great exciting force with high compacting efficiency.
- ★ Hydraulic steering, articulated frame with flexible steering and operation.
- ★ Adopt specific gearbox with synchronizer, big transmission torque, easy to shift gear.
- ★ Rear engine cover can be turned up for big angle for convenient maintenance.

\*We follows the principle of continuous improvement Product performance parameters will be partially changed due to technical improvements without prior notice.

